

Total number of printed pages: 3

D/First Semester/Paper Code: DME 104

2023

ENGINEERING DRAWING

Full Marks: 100

Time : Four hours

The figures in the margin indicate full marks for the questions.

Answer Question No.1 and any four of the following questions.

1.	Write the following sentence with free hand sketch in 35 mm height in single stroke vertical capital letter (7:4) INDIAN SPACE RESEARCH ORGANIZATION	20
2.	Draw the projections of the following points on the same ground line. A, in the V.P. and 50 mm above the H.P. B, 30 mm below the H.P. and 35 mm in front of the V.P. C, in the H.P. and 25 mm behind the V.P. D, 60 mm above the H.P. and 45 mm in front of the V.P. E, in the V.P. and 35 mm below the H.P. F, 50 mm above the H.P. and 50 mm behind the V.P. G, in the H.P. and 30 mm above the V.P. H, 35 mm below the H.P. and 45 mm behind the V.P.	20
3	a) Draw the projection of a 70 mm long straight line, in the following positions.	10
	(i) Inclined at 60 degrees to the V.P., in the H.P. and it's one end in the H.P.	
	(ii) Inclined at 45 degrees to the V.P. and it's one end 20 mm in front of it, parallel to and 25 mm above the H.P.	
b)	A straight line AB, 75 mm long makes an angle of 30 degree to the HP and 45 degree to the VP. The end A is 15 mm above HP and 12 mm in front of the VP. Draw its projections.	10

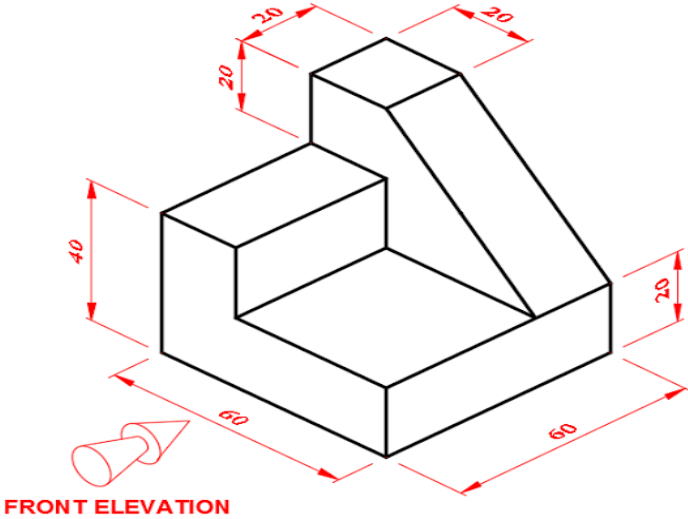
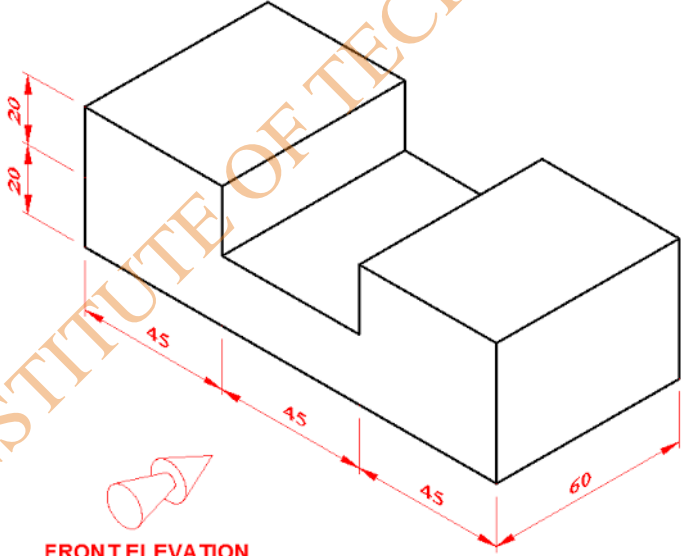
4.	<p>Draw the orthographic projection of the following figure for the Front view, Top view and Right hand side view using First Angle projection.</p>  <p style="text-align: center;">FRONT ELEVATION</p>	20
5.	<p>Draw the orthographic projection of the following figures for the Front view, Top view and Side view using First Angle projection.</p> <p>(i)</p>  <p style="text-align: center;">FRONT ELEVATION</p>	20

CENTRAL INSTITUTE OF TECHNOLOGY KOKRAJHAR

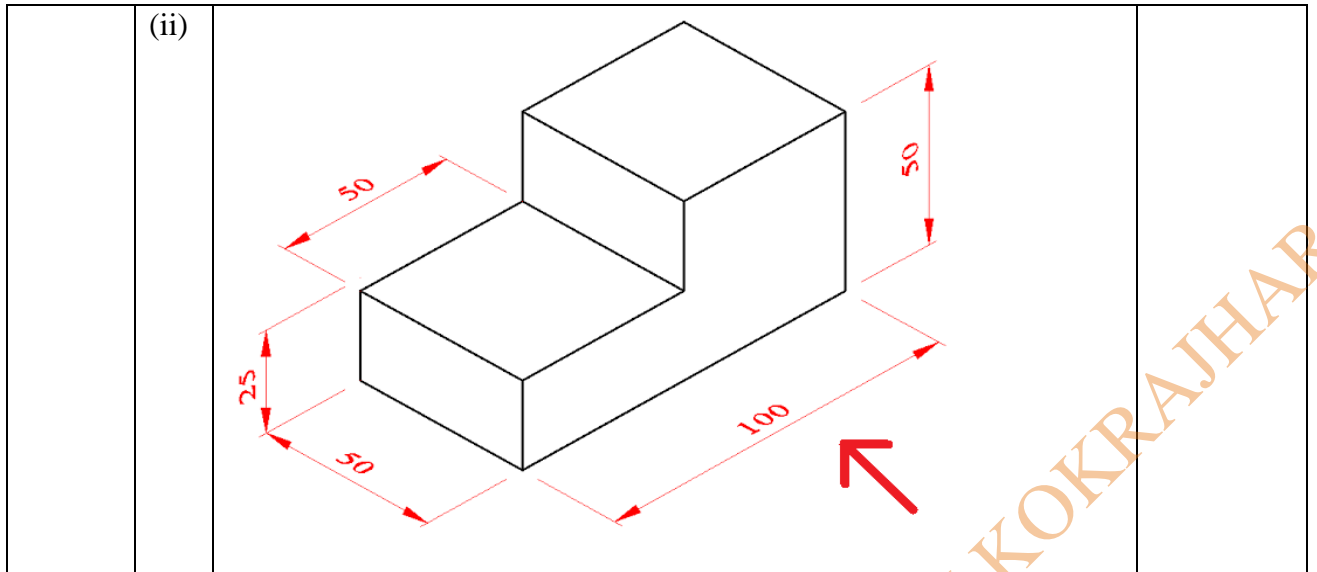

6.	Answer Any Two of the following.		20
a)	(i)	With the help of scale and compass draw a square of side 12 cm.	
	(ii)	Construct an equilateral triangle of altitude 10 cm.	
b)	Construct a regular pentagon of side 6 cm.		
c)	Construct a regular hexagon of side 5 cm.		

CENTRAL INSTITUTE OF TECHNOLOGY KOKRAJHAR