

2017

LINEAR INTEGRATED CIRCUIT C

Paper : EC 403

Full Marks : 100

Time : Three hours

The figures in the margin indicate full marks for the questions.

Answer **any five** questions out of **six**.

1. (a) Derive the expression for common mode and differential gain for the amplifier shown below : 7+7

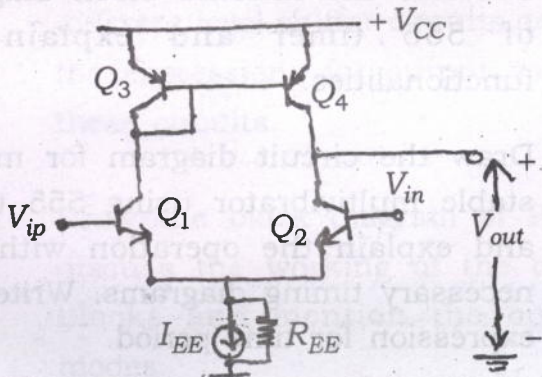

Contd.

- (b) Draw the internal schematic of $\mu A 741$ Op-Amp showing circuits for various stages. 6

2. (a) An ideal Op-Amp is used to make an amplifier as shown below. It is driven by $20V_{p-p}$, $1kHz$ triangular input, draw the input and output waveform, if the supply voltage used is $\pm 15V$. 3

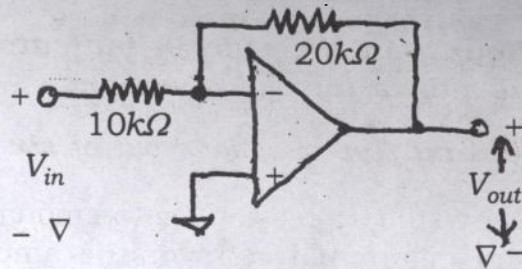

- (b) Describe the internal block diagram of 555 timer and explain its functionalities. 7
- (c) Draw the circuit diagram for mono-stable multivibrator using 555 timer and explain the operation with the necessary timing diagrams. Write the expression for time period. 10

3. (a) For the circuit shown below calculate the following parameters : 5

$$i_1, i_f, i_o, i_L, V_{out}$$

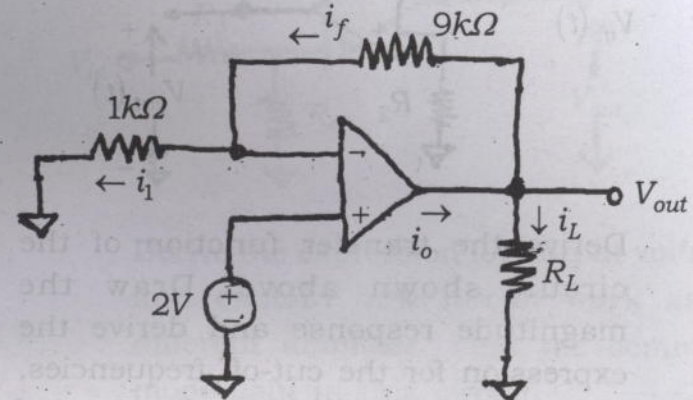

- (b) Why level shifters are necessary in multi-stage amplification? Mention different level shifter circuits and write the expressions for output voltage of these circuits. 2+3

- (c) Draw the block diagram of PLL and discuss the working of the different blocks and mention the operating modes. 10

4. (a)

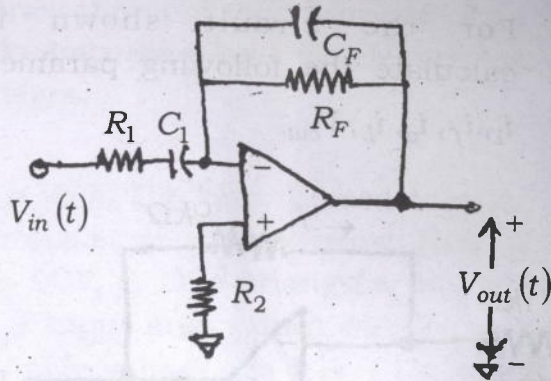

Derive the transfer function of the circuit shown above. Draw the magnitude response and derive the expression for the cut-off frequencies. What are the different applications of this circuit for various frequency ranges? 5+2+6+2

(b) Define the following terms and mention the typical values for a μA 741 Op-Amp : $PSRR$, $CMRR$, SR , V_{IO} , I_{IB} .

5

5. (a) Describe, how triangular wave can be generated using an Op-Amp in positive feedback. Explain the complete operation. 10

(b)

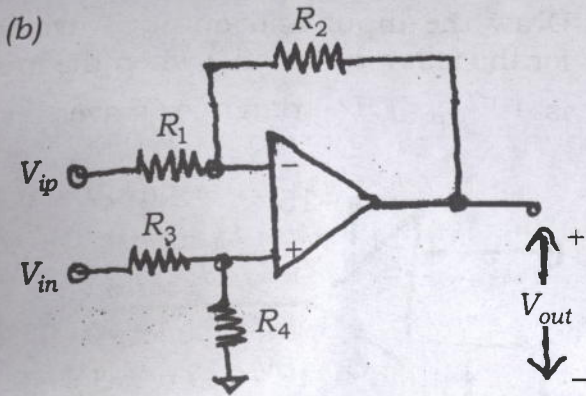

Derive the expression for output voltage and explain how it can work as a differential amplifier. Find the common mode gain in this circuit. 4+2+4

6. (a) An Op-Amp can be used to implement Voltage-Controlled-Voltage Source (VCVS), Voltage-Controlled-Current Source (VCCS), Current-Controlled Current Source (CCCS) and Current Controlled Voltage Source (CCVS). Draw the necessary circuit diagrams of these four types of implementation and derive the expressions for the respective output parameters. 16

- (b) Draw the input and output waveform for the following circuit ; when the input is $10V_{p.p}$, $1kHz$ triangular wave.

4

